



Rogers

Assessment Property Record Card for Tax Year 2026

Data provided by LISA DELOZIER County Assessor

Date 04/18/2026
 Time 11:22:20
 Page 1

Assessment Data					Primary Image																																																					
Account 660109205 Parcel ID 000418-0002-013-0-000-00 Cadastral ID 30-21-16-14480 Property Type REAL - Real Property Property Class URP VI Area 1 Tax Area 85 - CLRM SD-VERD TOWN/FIRE Name ID 348895 CISSNE, RUSSELL 10116 E BISWELL CT CLAREMORE OK 74019-0000 Parcel Location Situs 10116 E BISWELL CT Subdivision KING RIDGE V Lot/Block 0013 / 0002 Parcel Size 1 - Lots Sec/Twn/Rng 30 / 21 / 16 / 5 Neighborhood 1109 - R-V03-SW VERDIGRIS School District S001 - CLAREMORE SCHOOLS																																																										
Legal Description Lot/Long: 36.27605797 -95.64884264 LOT 13 BLOCK 2 KING RIDGE V																																																										
					Building Permits <table border="1"> <thead> <tr> <th>Number</th> <th>Description</th> <th>Opened</th> <th>Closed</th> <th>Amount</th> </tr> </thead> <tbody> <tr> <td>R25 010</td> <td>NEW SFR 11423 SQ FT</td> <td>04/2025</td> <td>09/2025</td> <td>147,000</td> </tr> </tbody> </table>					Number	Description	Opened	Closed	Amount	R25 010	NEW SFR 11423 SQ FT	04/2025	09/2025	147,000																																							
Number	Description	Opened	Closed	Amount																																																						
R25 010	NEW SFR 11423 SQ FT	04/2025	09/2025	147,000																																																						
Exemptions <table border="1"> <thead> <tr> <th>Code</th> <th>Type</th> <th>Active</th> <th>Maximum</th> <th>Exemption</th> </tr> </thead> <tbody> <tr> <td></td> <td></td> <td></td> <td></td> <td></td> </tr> </tbody> </table>					Code	Type	Active	Maximum	Exemption						Sale History <table border="1"> <thead> <tr> <th>Bk/Pg</th> <th>Grantor</th> <th>Date</th> <th>Price</th> <th>Code</th> </tr> </thead> <tbody> <tr> <td>/</td> <td>LENNAR HOMES OF OKLAHOMA LLC</td> <td>12/05/2025</td> <td>216,000</td> <td>15</td> </tr> <tr> <td>/</td> <td>TULSA L DEV LLC</td> <td>03/26/2025</td> <td>173,500</td> <td>15</td> </tr> <tr> <td>/</td> <td>RAUSCH COLEMAN HOMES OF TULSA</td> <td>01/15/2025</td> <td></td> <td>15</td> </tr> <tr> <td>/</td> <td>TULSA L DEV LLC</td> <td>06/26/2024</td> <td>0</td> <td>WB</td> </tr> </tbody> </table>					Bk/Pg	Grantor	Date	Price	Code	/	LENNAR HOMES OF OKLAHOMA LLC	12/05/2025	216,000	15	/	TULSA L DEV LLC	03/26/2025	173,500	15	/	RAUSCH COLEMAN HOMES OF TULSA	01/15/2025		15	/	TULSA L DEV LLC	06/26/2024	0	WB														
Code	Type	Active	Maximum	Exemption																																																						
Bk/Pg	Grantor	Date	Price	Code																																																						
/	LENNAR HOMES OF OKLAHOMA LLC	12/05/2025	216,000	15																																																						
/	TULSA L DEV LLC	03/26/2025	173,500	15																																																						
/	RAUSCH COLEMAN HOMES OF TULSA	01/15/2025		15																																																						
/	TULSA L DEV LLC	06/26/2024	0	WB																																																						
Parcel Valuation <table border="1"> <thead> <tr> <th>Source</th> <th>REAL</th> <th>Fair Cash</th> <th>Capped</th> <th>Asmnt Level</th> <th>Assessed</th> <th>Levy Rate</th> <th>109.172</th> <th>Current Tax</th> </tr> </thead> <tbody> <tr> <td>Remove Cap</td> <td>2026</td> <td>Land Value</td> <td>45,878</td> <td>45,878</td> <td>11%</td> <td>5,047</td> <td>Assessed</td> <td>12,532</td> <td>1,368.14</td> </tr> <tr> <td>Year Frozen</td> <td></td> <td>Improvements</td> <td>68,049</td> <td>68,049</td> <td></td> <td>7,485</td> <td>Penalty</td> <td>0</td> <td></td> </tr> <tr> <td>Uncapped Value</td> <td>68,049</td> <td>Mobile Home</td> <td>0</td> <td>0</td> <td></td> <td>0</td> <td>Exemption</td> <td>0</td> <td>0.00</td> </tr> <tr> <td>TIF Project ID</td> <td>0</td> <td>Total Value</td> <td>113,927</td> <td>113,927</td> <td></td> <td>12,532</td> <td>Total Taxable</td> <td>12,532</td> <td>1,368.00</td> </tr> </tbody> </table>										Source	REAL	Fair Cash	Capped	Asmnt Level	Assessed	Levy Rate	109.172	Current Tax	Remove Cap	2026	Land Value	45,878	45,878	11%	5,047	Assessed	12,532	1,368.14	Year Frozen		Improvements	68,049	68,049		7,485	Penalty	0		Uncapped Value	68,049	Mobile Home	0	0		0	Exemption	0	0.00	TIF Project ID	0	Total Value	113,927	113,927		12,532	Total Taxable	12,532	1,368.00
Source	REAL	Fair Cash	Capped	Asmnt Level	Assessed	Levy Rate	109.172	Current Tax																																																		
Remove Cap	2026	Land Value	45,878	45,878	11%	5,047	Assessed	12,532	1,368.14																																																	
Year Frozen		Improvements	68,049	68,049		7,485	Penalty	0																																																		
Uncapped Value	68,049	Mobile Home	0	0		0	Exemption	0	0.00																																																	
TIF Project ID	0	Total Value	113,927	113,927		12,532	Total Taxable	12,532	1,368.00																																																	
Assessment History <table border="1"> <thead> <tr> <th>Tax Year</th> <th>Statement Number</th> <th>Billed Owner</th> <th>Tax Area</th> <th>Total Value</th> <th>Exemptions</th> <th>Taxable Value</th> <th>Billed Tax</th> </tr> </thead> <tbody> <tr> <td>2025</td> <td>2025-660109205</td> <td>LENNAR HOMES OF OKLAHOMA LLC</td> <td>85</td> <td>7,304</td> <td>0</td> <td>803</td> <td>87.00</td> </tr> </tbody> </table>										Tax Year	Statement Number	Billed Owner	Tax Area	Total Value	Exemptions	Taxable Value	Billed Tax	2025	2025-660109205	LENNAR HOMES OF OKLAHOMA LLC	85	7,304	0	803	87.00																																	
Tax Year	Statement Number	Billed Owner	Tax Area	Total Value	Exemptions	Taxable Value	Billed Tax																																																			
2025	2025-660109205	LENNAR HOMES OF OKLAHOMA LLC	85	7,304	0	803	87.00																																																			



Rogers

Assessment Property Record Card for Tax Year 2026

Data provided by LISA DELOZIER County Assessor

Date 04/18/2026
 Time 11:22:20
 Page 2

Lot Data		Square-Foot - NBHD 1109 #1	
Lot Size	0	0	
Lot Count	1		
Units Buildable			
Non-Ag Acres	0.1761		
Topography			
Street Access			
Utilities			
Amenities			
Method	Square-Foot		
Base Lot Value	7,672.00 x 5.90 = 45,227		
Factor Value			
Adjustments	1.0144		
Lot Value	45,878		



660109205_001.JPG 9/24/2025

Residential Data	
Type	1 Single Family Residence
Condition	3 - Average
Quality	2.5 - Fair
Architecture	
Style	100% One Story
Exterior Wall	75% Frame, Siding, Vinyl 25% Veneer, Masonry
Base/Total Area	1,210 / 1,210
Style	100% One Story
HVAC	100% Warmed & Cooled Air
Roof Cover	1 Composition Shingle
Area on Slab	1,210
Fixture/RghIn	/
Bed/F/H Bath	3 / 2.0 /
Basement Area	
Garage Type	389 Attached Garage - Finished
Remodel	
Year/Eff Age	2025 / 1

GRM Approach	
GRM Code	
Gross Rent	0.00
Indicated Value	

Multiple Regression	
MRA Code	
Adjusted R	
Indicated Value	

Direct Comparables	
Selection Model	A Adam Test
Adjustment Model	1 2022 Residential
Comparables	
Indicated Value	

Cost Approach				Manual : 01/2025			
Base Cost	104.87	Total Misc Impr	+ 2,005				
Roofing Adj	+ 4.75	Garage Cost	+ 14,362				
Subfloor Adj	+ -1.22	Total RCN	= 171,840				
Heat/Cool Adj	+ 11.47	Depreciation (1%)	- 1,718				
Plumbing Adj	+ 8.62	Lump Sums	+ 0				
Basement Adj	+ 0.00	RCNLD	= 170,122				
Adj Base Cost	= 128.49	Lot Value	+ 45,878				
Total Area	x 1,210	Indicated Value	= 216,000				
Adjusted Cost	= 155,473	Value Per SqFt	178.51				

Value Reconciliation			
Selected Approach	Cost Approach		
Improvements	170,122		
Lot Value	45,878		
Indicated Value	216,000	178.51	Per SqFt
Agland Value			
Site Improvements			
Total Value	216,000	178.51	Total Value Per SqFt

Miscellaneous Improvements							
Code	Description	Sketch ID	Size	Year	Units	Unit Cost	Depr Value
PRCH	Porch	176203	13x3		39	24.14	941
PATO	Patio - Open	176204	14x7		98	10.86	1,064



Rogers

Assessment Property Record Card for Tax Year 2026

Data provided by LISA DELOZIER County Assessor

Date 04/18/2026
 Time 11:22:20
 Page 3

Sketch Image

660109205

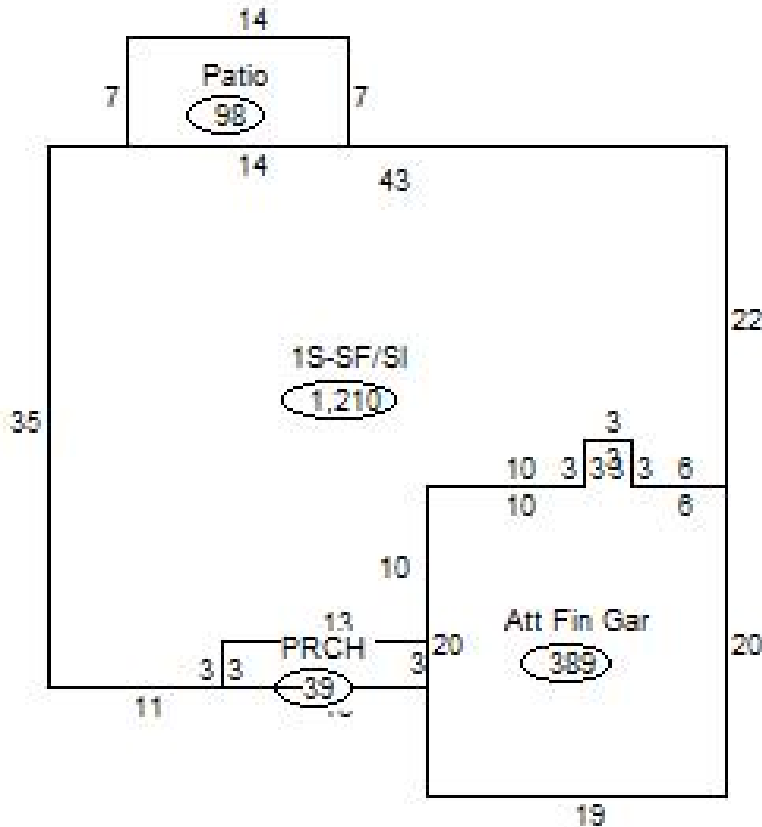

Sketch Vector Information

Sequence	Code	Type	Built Over	Scale	Section Label	Base Area	Multiplier	Total Area
1	R	1	Slab	20	1S-SF/Sl	1,210	1.000	1,210
2	G	5		20	Att Fin Gar	389	1.000	389
3	M	PRCH		20	PRCH	39	1.000	39
4	M	PATO		20	Patio	98	1.000	98
Total Building Area						1,210		1,210