



Rogers

Assessment Property Record Card for Tax Year 2026

Data provided by LISA DELOZIER County Assessor

Date 04/18/2026
Time 11:23:20
Page 1

Assessment Data					Primary Image																																																																
Account 660109239 Parcel ID 000418-0004-018-0-000-00 Cadastral ID 30-21-16-14820 Property Type REAL - Real Property Property Class URP VI Area 1 Tax Area 85 - CLRM SD-VERD TOWN/FIRE Name ID 347931 WEHR, RYAN & RACHEL 23184 S MAE DR CLAREMORE OK 74019-0000 Parcel Location Situs 23184 S MAE DR Subdivision KING RIDGE V Lot/Block 0018 / 0004 Parcel Size 1 - Lots Sec/Twn/Rng 30 / 21 / 16 / 5 Neighborhood 1109 - R-V03-SW VERDIGRIS School District S001 - CLAREMORE SCHOOLS					<p>660109239 09/24/25</p> <p>660109239_001.JPG 9/24/2025</p>																																																																
Legal Description Lot/Long: 36.27579163 -95.64956860 LOT 18 BLOCK 4 KING RIDGE V																																																																					
Exemptions <table border="1"> <thead> <tr> <th>Code</th> <th>Type</th> <th>Active</th> <th>Maximum</th> <th>Exemption</th> </tr> </thead> <tbody> <tr> <td>H</td> <td>Homestead</td> <td>Yes</td> <td>1,000</td> <td>1,000</td> </tr> </tbody> </table>					Code	Type	Active	Maximum	Exemption	H	Homestead	Yes	1,000	1,000	Building Permits <table border="1"> <thead> <tr> <th>Number</th> <th>Description</th> <th>Opened</th> <th>Closed</th> <th>Amount</th> </tr> </thead> <tbody> <tr> <td>R25 019</td> <td>NEW SFR 1940 SQ FT</td> <td>05/2025</td> <td>09/2025</td> <td>165,000</td> </tr> </tbody> </table>					Number	Description	Opened	Closed	Amount	R25 019	NEW SFR 1940 SQ FT	05/2025	09/2025	165,000																																								
Code	Type	Active	Maximum	Exemption																																																																	
H	Homestead	Yes	1,000	1,000																																																																	
Number	Description	Opened	Closed	Amount																																																																	
R25 019	NEW SFR 1940 SQ FT	05/2025	09/2025	165,000																																																																	
Parcel Valuation <table border="1"> <thead> <tr> <th>Source</th> <th>REAL</th> <th>Fair Cash</th> <th>Capped</th> <th>Asmnt Level</th> <th>Assessed</th> <th>Levy Rate</th> <th>109.172</th> <th>Current Tax</th> </tr> </thead> <tbody> <tr> <td>Remove Cap</td> <td>2026</td> <td>Land Value</td> <td>41,554</td> <td>41,554</td> <td>11%</td> <td>4,571</td> <td>Assessed</td> <td>31,130 3,398.52</td> </tr> <tr> <td>Year Frozen</td> <td></td> <td>Improvements</td> <td>241,445</td> <td>241,445</td> <td></td> <td>26,559</td> <td>Penalty</td> <td>0</td> </tr> <tr> <td>Uncapped Value</td> <td>241,445</td> <td>Mobile Home</td> <td>0</td> <td>0</td> <td></td> <td>0</td> <td>Exemption</td> <td>1,000 -93.00</td> </tr> <tr> <td>TIF Project ID</td> <td>0</td> <td>Total Value</td> <td>282,999</td> <td>282,999</td> <td></td> <td>31,130</td> <td>Total Taxable</td> <td>30,130 3,306.00</td> </tr> </tbody> </table>					Source	REAL	Fair Cash	Capped	Asmnt Level	Assessed	Levy Rate	109.172	Current Tax	Remove Cap	2026	Land Value	41,554	41,554	11%	4,571	Assessed	31,130 3,398.52	Year Frozen		Improvements	241,445	241,445		26,559	Penalty	0	Uncapped Value	241,445	Mobile Home	0	0		0	Exemption	1,000 -93.00	TIF Project ID	0	Total Value	282,999	282,999		31,130	Total Taxable	30,130 3,306.00	Sale History <table border="1"> <thead> <tr> <th>Bk/Pg</th> <th>Grantor</th> <th>Date</th> <th>Price</th> <th>Code</th> </tr> </thead> <tbody> <tr> <td>/</td> <td>RAUSCH COLEMAN HOMES OF TULSA</td> <td>08/19/2025</td> <td>280,000</td> <td>15</td> </tr> <tr> <td>/</td> <td>TULSA L DEV LLC</td> <td>06/26/2024</td> <td>0</td> <td>WB</td> </tr> </tbody> </table>					Bk/Pg	Grantor	Date	Price	Code	/	RAUSCH COLEMAN HOMES OF TULSA	08/19/2025	280,000	15	/	TULSA L DEV LLC	06/26/2024	0	WB
Source	REAL	Fair Cash	Capped	Asmnt Level	Assessed	Levy Rate	109.172	Current Tax																																																													
Remove Cap	2026	Land Value	41,554	41,554	11%	4,571	Assessed	31,130 3,398.52																																																													
Year Frozen		Improvements	241,445	241,445		26,559	Penalty	0																																																													
Uncapped Value	241,445	Mobile Home	0	0		0	Exemption	1,000 -93.00																																																													
TIF Project ID	0	Total Value	282,999	282,999		31,130	Total Taxable	30,130 3,306.00																																																													
Bk/Pg	Grantor	Date	Price	Code																																																																	
/	RAUSCH COLEMAN HOMES OF TULSA	08/19/2025	280,000	15																																																																	
/	TULSA L DEV LLC	06/26/2024	0	WB																																																																	
Assessment History <table border="1"> <thead> <tr> <th>Tax Year</th> <th>Statement Number</th> <th>Billed Owner</th> <th>Tax Area</th> <th>Total Value</th> <th>Exemptions</th> <th>Taxable Value</th> <th>Billed Tax</th> </tr> </thead> <tbody> <tr> <td>2025</td> <td>2025-660109239</td> <td>WEHR, RYAN & RACHEL</td> <td>85</td> <td>7,304</td> <td>0</td> <td>803</td> <td>87.00</td> </tr> </tbody> </table>					Tax Year	Statement Number	Billed Owner	Tax Area	Total Value	Exemptions	Taxable Value	Billed Tax	2025	2025-660109239	WEHR, RYAN & RACHEL	85	7,304	0	803	87.00																																																	
Tax Year	Statement Number	Billed Owner	Tax Area	Total Value	Exemptions	Taxable Value	Billed Tax																																																														
2025	2025-660109239	WEHR, RYAN & RACHEL	85	7,304	0	803	87.00																																																														



Rogers

Assessment Property Record Card for Tax Year 2026

Data provided by LISA DELOZIER County Assessor

Date 04/18/2026
 Time 11:23:21
 Page 2

Lot Data		Square-Foot - NBHD 1109 #1	
Lot Size	0	0	
Lot Count	1		
Units Buildable			
Non-Ag Acres	0.2442		
Topography			
Street Access			
Utilities			
Amenities			
Method	Square-Foot		
Base Lot Value	10,636.00 x 5.14 = 54,647		
Factor Value			
Adjustments	0.7604		
Lot Value	41,554		



660109239_001.JPG 9/24/2025

Residential Data	
Type	1 Single Family Residence
Condition	3 - Average
Quality	2.5 - Fair
Architecture	
Style	100% One Story
Exterior Wall	75% Frame, Siding, Vinyl 25% Veneer, Masonry
Base/Total Area	1,940 / 1,940
Style	100% One Story
HVAC	100% Warmed & Cooled Air
Roof Cover	1 Composition Shingle
Area on Slab	1,940
Fixture/RghIn	/
Bed/F/H Bath	4 / 2.0 /
Basement Area	
Garage Type	412 Attached Garage - Finished
Remodel	
Year/Eff Age	2025 / 1

GRM Approach	
GRM Code	
Gross Rent	0.00
Indicated Value	

Multiple Regression	
MRA Code	
Adjusted R	
Indicated Value	

Direct Comparables	
Selection Model	A Adam Test
Adjustment Model	1 2022 Residential
Comparables	
Indicated Value	

Cost Approach		Manual : 01/2025	
Base Cost	94.76	Total Misc Impr	+ 6,223
Roofing Adj	+ 4.29	Garage Cost	+ 14,968
Subfloor Adj	+ -1.11	Total RCN	= 243,884
Heat/Cool Adj	+ 11.47	Depreciation (1%)	- 2,439
Plumbing Adj	+ 5.38	Lump Sums	+ 0
Basement Adj	+ 0.00	RCNLD	= 241,445
Adj Base Cost	= 114.79	Lot Value	+ 41,554
Total Area	x 1,940	Indicated Value	= 282,999
Adjusted Cost	= 222,693	Value Per SqFt	145.88

Value Reconciliation			
Selected Approach	Cost Approach		
Improvements	241,445		
Lot Value	41,554		
Indicated Value	282,999	145.88	Per SqFt
Agland Value			
Site Improvements			
Total Value	282,999	145.88	Total Value Per SqFt

Miscellaneous Improvements								
Code	Description	Sketch ID	Size	Year	Units	Unit Cost	Depr	Value
PRCH	Porch	176223	168		168	23.69		3,980
PATC	Patio - Covered	176224	20x6		120	18.69		2,243



Rogers
Assessment Property Record Card for Tax Year 2026
 Data provided by LISA DELOZIER County Assessor

Date 04/18/2026
 Time 11:23:21
 Page 3

Sketch Image

660109239

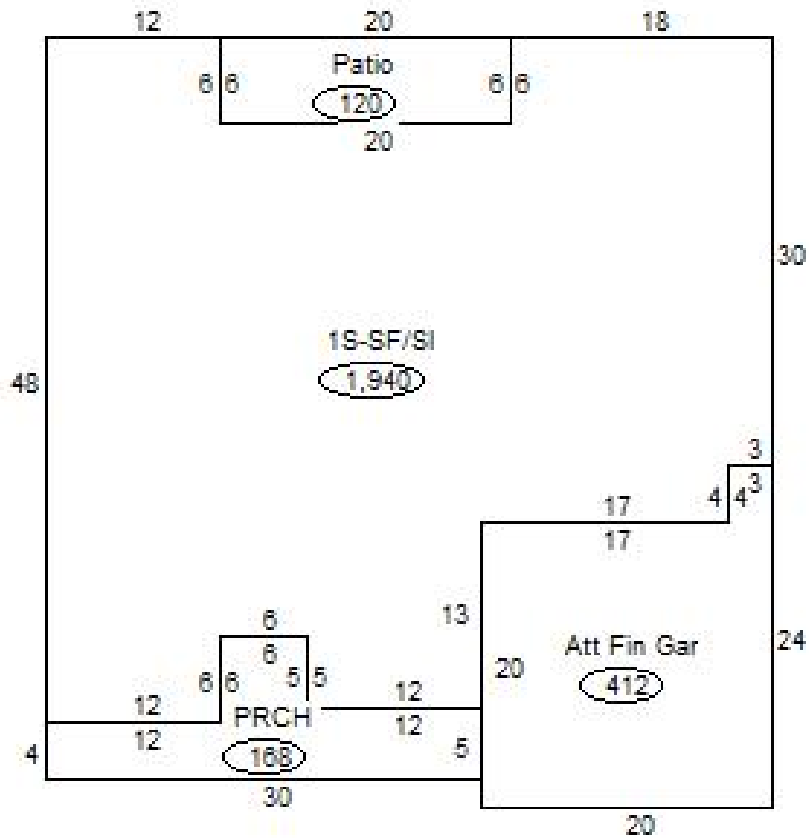

Sketch Vector Information

Sequence	Code	Type	Built Over	Scale	Section Label	Base Area	Multiplier	Total Area
1	R	1	Slab	20	1S-SF/Sl	1,940	1.000	1,940
2	G	5		20	Att Fin Gar	412	1.000	412
3	M	PRCH		20	PRCH	168	1.000	168
4	M	PATC		20	Patio	120	1.000	120
Total Building Area						1,940		1,940